

---

# DVOP 8 channels Digital Video/Audio/Data Fiber Optical Transmitter and Receiver

## Profile

DVOP-08 series of products provide uncompressed high quality transmission systems for 8 channels of digitalized analog video, up to 32 channels of bi-directional data and audio signals, 4 channels E1/T1 and 10/100M self-adaptive Ethernet data over one single mode or multimode optic fiber, DVOP-08 is a



multi-function product which based on highly reliable large -scale specialized ICs designed by ourselves. It's extremely flexible with the ability to add/drop video, audio, RS232/RS422/RS485, E1, 100M Ethernet ports via plugging in/out our fieldproven service cards. Compared with the same kind of analog transmission systems that employ accidental amplitude or frequency modulation, DVOP -08 products provide better transmission in quality.

The various types of DVOP08 products can meet different user's demands. Adopts advanced digital fiber optic transmission technologies, DVOP-08 devices can be installed rapidly without customer adjusting, and they are easy to operate and maintain. On the front panel of the products are video connector (BNC), audio and data connector (RJ45 or Terminal Plug with screw clamps), and fiber optic connector (FC -single mode or SC-multimode). Users can easily monitor the status of power supply, connection and channels through the indicator lights. There are two types of DVOP-08 available: standalone and card type.

## Product Characteristics

- ◆ Digital Fiber transmission platform, Multi-operation flexible setting, Save investment to build complex network
  - ◆ No EMI, RFI etc
-

- ◆ Support Audio, Data, Phone etc cross connection function and remote set on management platform
- ◆ Perfect High-grade Thunderbolt, Surge, ESD protection design to ensure long time stable working
- ◆ Good Data, Audio, Ethernet, Phone, Talk-back etc electromagnetism compatible feature
- ◆ Large-scale Proprietary IC Core and high-speed DSP technique
- ◆ Support 24bits DVD format; high-dynamic range, stereo Audio signal
- ◆ Auto-switch Fiber protection (<20ms),improve the reliability of system
- ◆ Support Audio, Data regenerate and relay
- ◆ Support base-on SNMP e-MS management system, convenient surveillance management of big network
- ◆ SNMP system has powerful functions, simple user interface
- ◆ Modularized and industrialized design ensuring reliability and flexibility
- ◆ Adopt WDM/CWDM/DWDM technique
- ◆ 10 digit coding and non-compression video transmission
- ◆ Auto PAL/NTSC/SECAM Compatible
- ◆ Indicators for Power Supply, Video, Optic-link and Data-loop
- ◆ Large capacity of gigabit optical fiber transmission allowing of easy upgrade
- ◆ Card type, Stand-alone type,19 inch 1U/2U standard case and 4U chassis optional

## Ordering Information

No	Model	Amount
1	Video	8
2	RS485	20
3	RS232	20
4	RS422	12
5	Audio	16
6	Ethernet	1
7	I/O	12
8	Phone	8
9	CAN	2
10	External expansion interfaces	4
11	EMS	Yes

No	Model	Specifications
1	DVOP-N06-DD1	6channel video and 1channel Uni-Direction date
2	DVOP-N08-DD1	8channel video and 1channel Uni-Direction date
3	DVOP-N08-AB4	8channel video and 4channel Bi-Direction audio
4	DVOP-N08-DB2	8 channel video and 2channel channel video date
5	.....	.....

---

## Application Area

- ◆ High way & Tall station surveillance
- ◆ Speedway & Railway remote surveillance
- ◆ Public security surveillance
- ◆ Surveillance and cable TV system
- ◆ Intelligent traffic monitor system
- ◆ High quality video conference
- ◆ Broadcast and TV program transmission
- ◆ Long-distance multimedia teaching
- ◆ Industrial Closed Circuit Television Surveillance
- ◆ Custom, Airport, Warehouse video monitor
- ◆ Supermarket, Bank Hall & ATM machines video surveillance
- ◆ Smart building, Government office etc safety & protection system

## Technical Parameters

### 1. Optical Channel Technical Specifications: (Table 1)

Wavelength	850nm / 1310nm / 1550nm
Distance	MM: 0-2km, SM: 0-100km
Power	-15~-10dBm / -10~-5dBm / -5~+3dBm (SM); -19~-14dBm (MM)
Receiving Sensitivity	-34~-38dBm
Optical Dynamic Range	20~40dB
Maximum Optical Loss	18~38dB

### 2. 视频通道技术指标: (表 2)

Video Format	PAL/NTSC/SECAM Auto compatible
Video Bandwidth	10MHz
Video Sampling	20MHz
Differential Gain	DG < 1%
Differential Phase	DP < 0.7°
Video signal to noise ratio	S/N ≥ 65dB

### 3. Data Channel Specification: (Table 3)

Interface type	RS-232/422/485/ Manchester Biphase
Code rate	0~2Mbps
BER	≤ 10 <sup>-12</sup>

### 4. Technical indicators for the audio channels: (Table 4)

---

Input / Output Voltage	0.5VP-P—4VP-P
Audio Bandwidth	10Hz~20kHz
Distortion	<0.1%
Audio signal to noise ratio	S/N≥80db
Audio Coding	24Bit

#### 5. Connection terminals: (Table 6)

Optical Interface	FC/ST/SC
Video Interface	BNC
Data Interface	DB9/DB25/ Industrial pressure connector
Audio Interface	Pressure connector /RCA
Ethernet	RJ45
Binary	Industrial pressure connector /RJ45

#### 6. Voltage: (Table 7)

AC supply voltage	220VAC±30% 50HZ
DC	5-12VDC±20%
Power	≤ 3W

#### 7. Work environment (Table 8)

Work Temperature	-40 °C~+75 °C
Storage Temperature	-40 °C~+85 °C
Relative Humidity	≤95% (No cold condensation)

#### 8. EMC (Table 9)

Susceptibility	EN50130-4、50028-1
Radiation	EN50081-1、EN55022-B、CCC
MTBF: >100000 hours	

#### 9. Physical Characteristics: (Table 10)

Work Temperature	-40°C~85°C
Storage Temperature	-55°C~95°C
Humidity	0~95% Non-condensing
Hot flashes	BS2011
Induction	EN50130-5, 1995

#### 10. Machine Size (Table 11)

Transmitter	196mm×155mm×45mm
Receive	196mm×155mm×45mm
Receiver rack	480mm×290mm×200mm
Receiver Frame	19 Inch 4.5U, High Density, The largest business with 21 slots

Description

Optional dual power supplies, Power Built-in.  
If you need to EMS, there are only 20 slots.

## Typical Application Diagrams

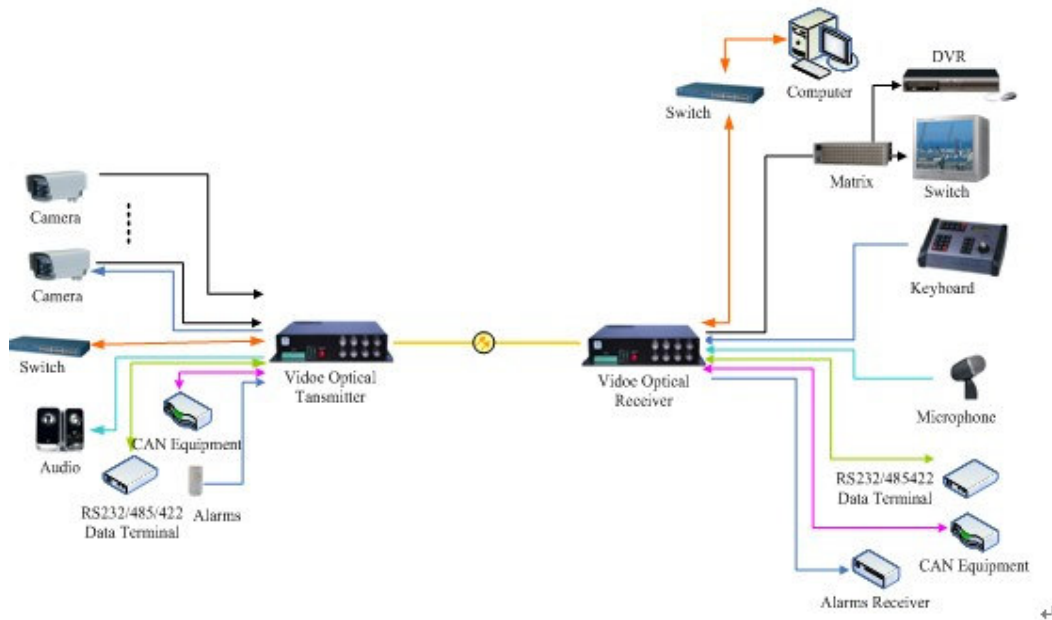

Common stand-alone application diagram

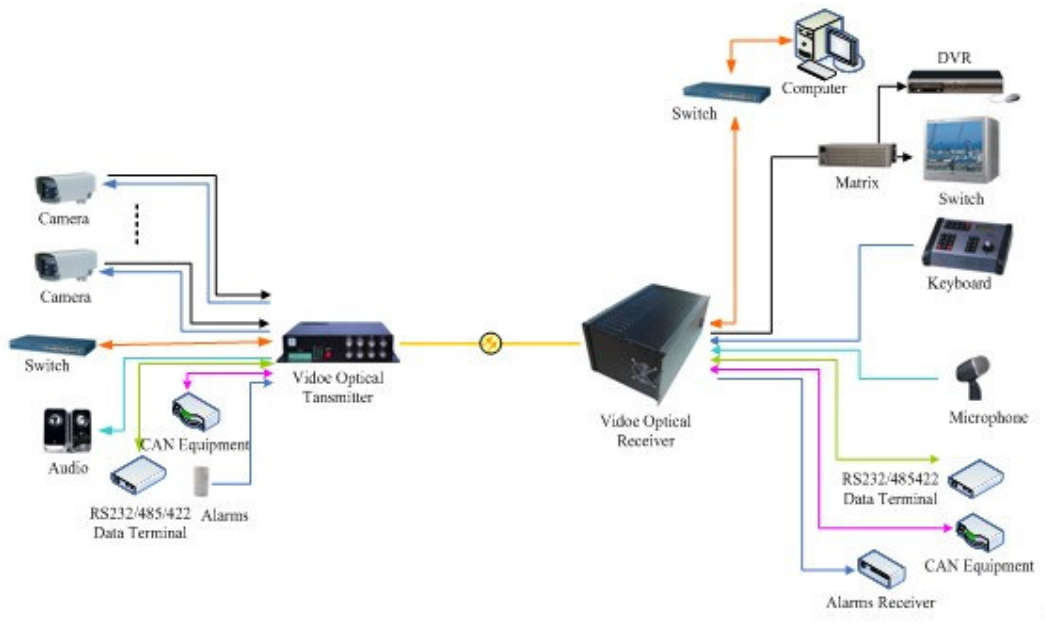

Common type rack-mount application diagram↵